

NOTES: (unless otherwise specified)

1. All dimensions in MM
2. Deburr and break all sharp edges
3. MATERIAL:
4. FINISH:

REVISIONS:

**cyclehoop**

T: 0208 699 1338 E: info@cyclehoop.com

Copyright © 2017 Cyclehoop Ltd.  
All materials contained are the property of Cyclehoop Ltd. and are protected by copyright.  
Prior written consent must be obtained for any use of the material.

TITLE:  
**Bikehangar GA**

DESCRIPTION:  
**GA - Closed**

DATE:  
**10/12/2017**

DRAWN BY: **TJ** | REV:

SHEET: **1 OF 2** | SCALE: **1:20 AT A3**

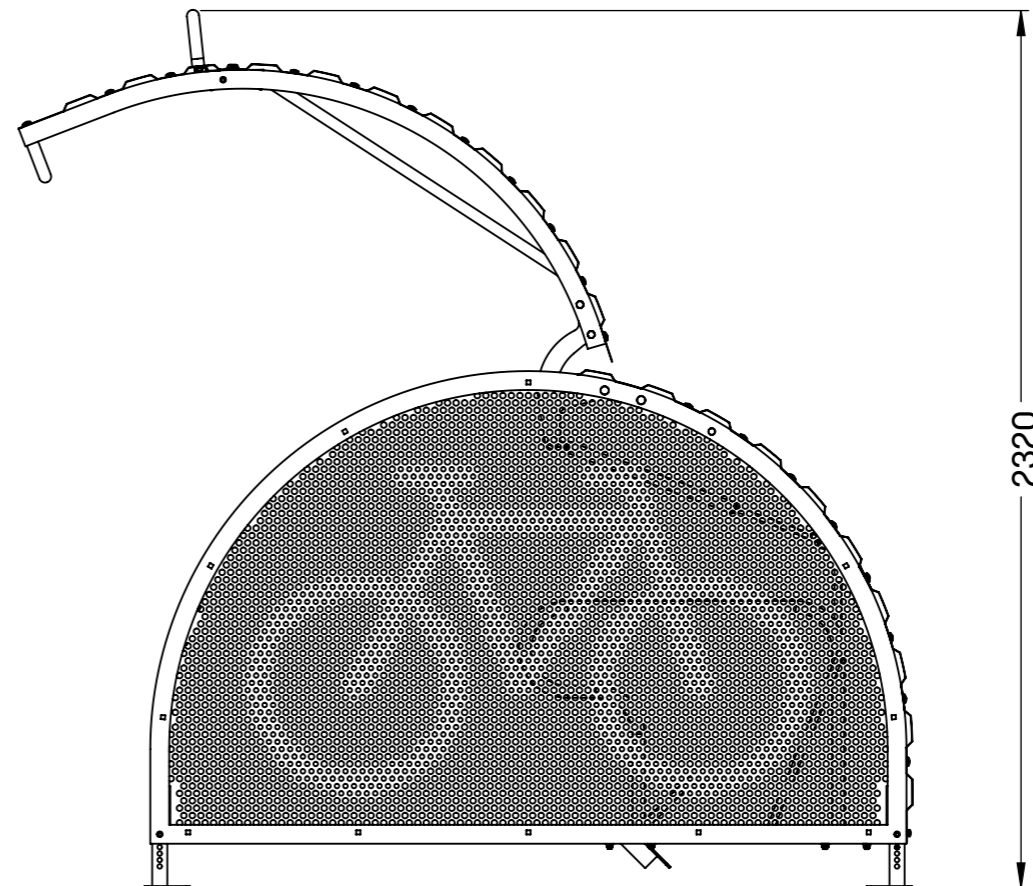
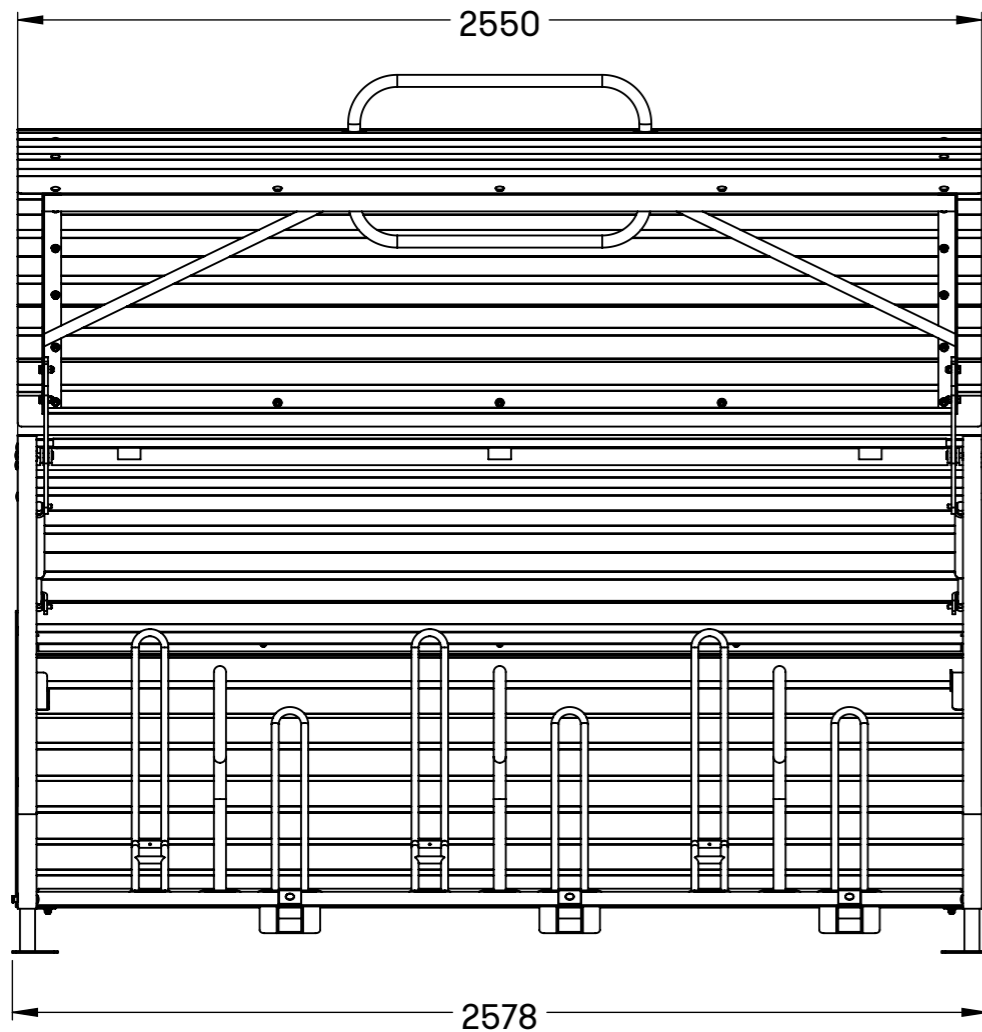
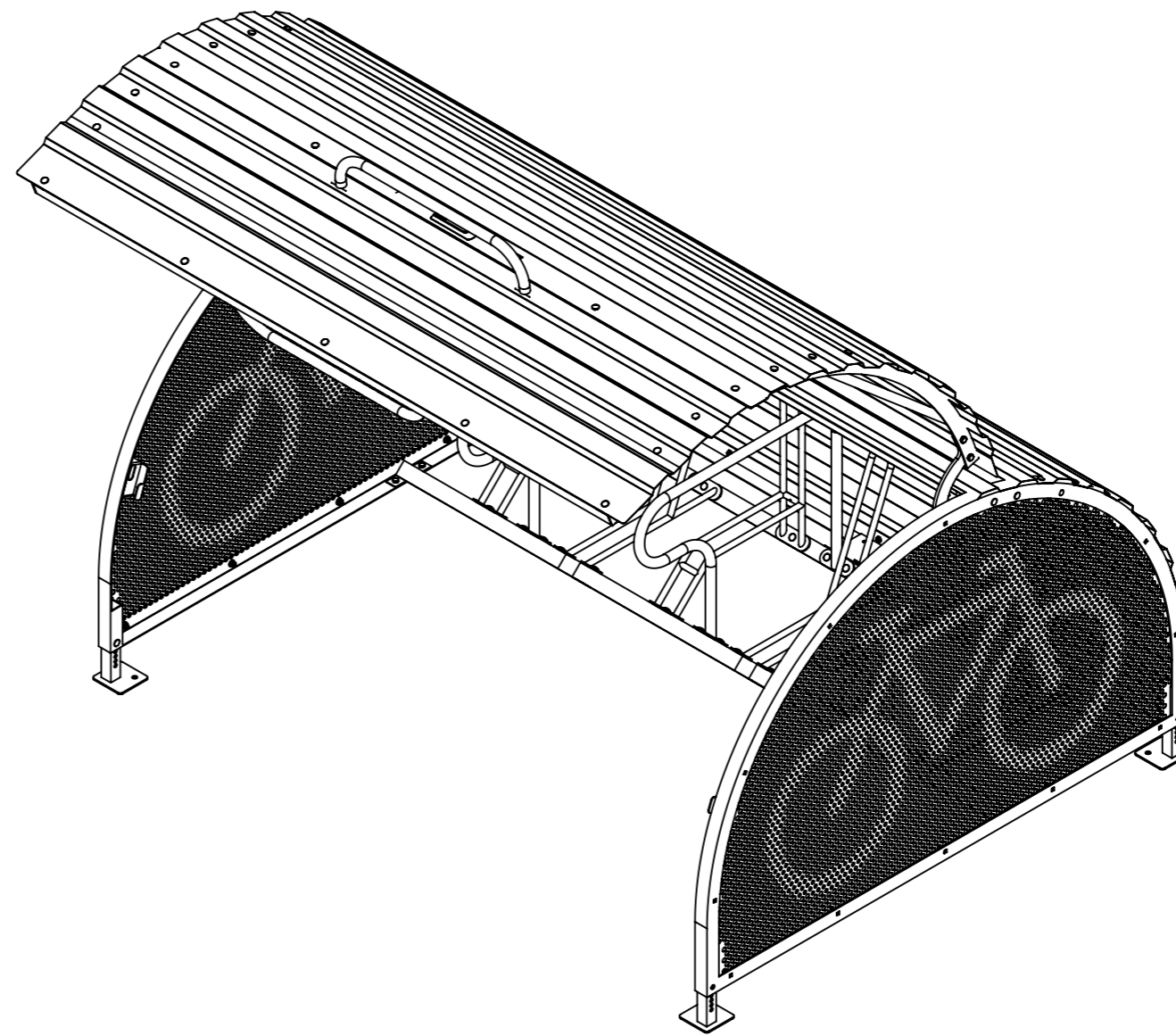
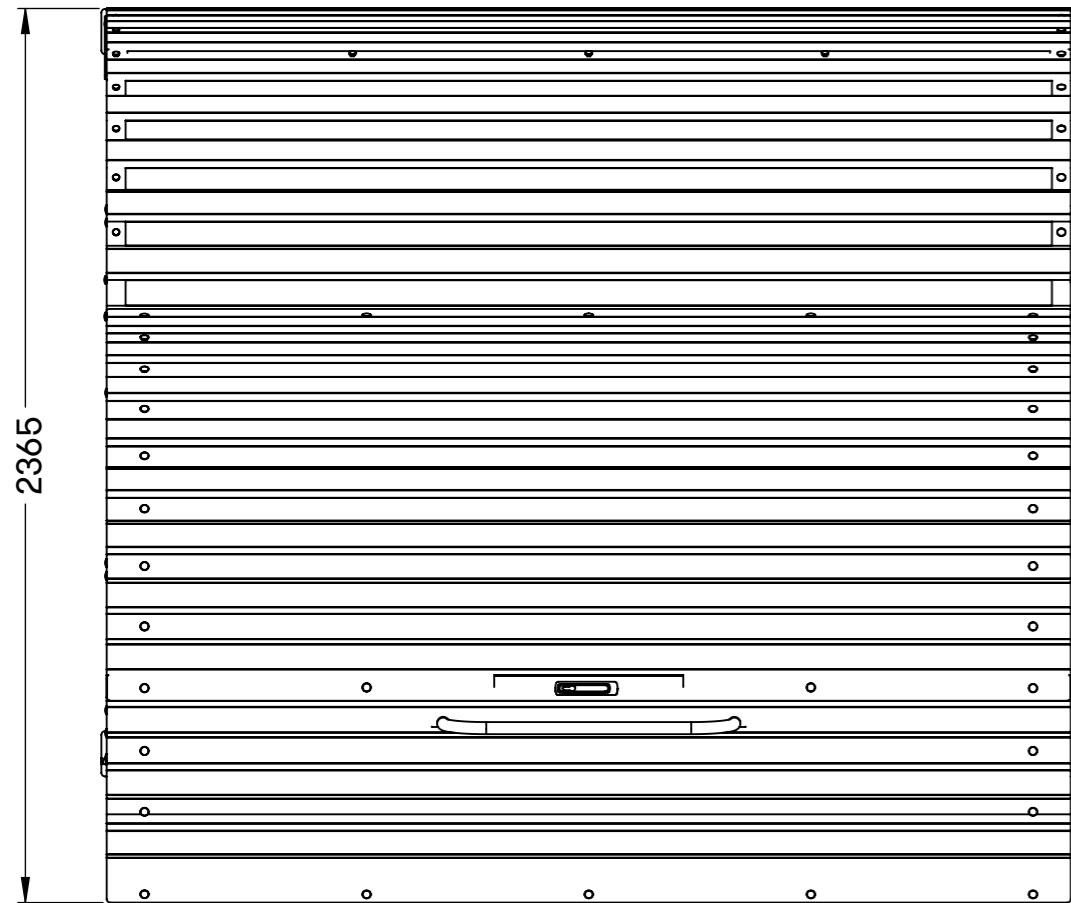

NOTES: (unless otherwise specified)

1. All dimensions in MM
2. Deburr and break all sharp edges
3. MATERIAL:
4. FINISH:

REVISIONS:



T: 0208 699 1338 E: info@cyclehoop.com  
 Copyright © 2017 Cyclehoop Ltd.  
 All materials contained are the property of Cyclehoop Ltd. and are protected by copyright.  
 Prior written consent must be obtained for any use of the material.

TITLE:  
 Bikehangar GA

DESCRIPTION:  
 GA - Open

DATE:  
 10/12/2017

DRAWN BY: TJ | REV:

SHEET: 2 OF 2 | SCALE: 1:20 AT A3